

OPERATING MANUEL
STANDARDBOX Series 600

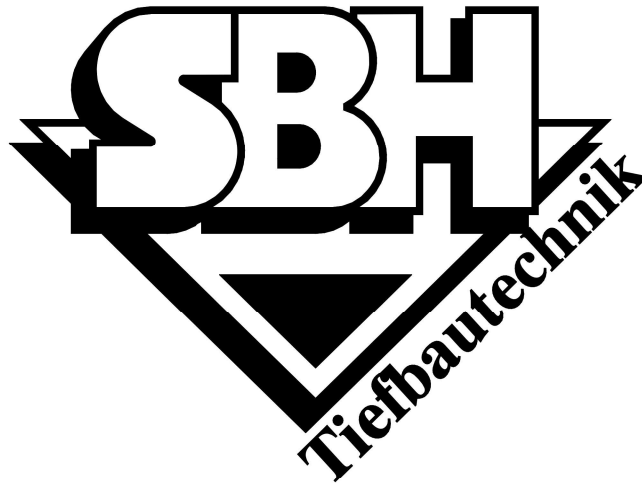

manufacturer: **SBH Tiefbautechnik GmbH**
Ferdinand-Porsche-Str. 8
D – 52525 HEINSBERG

phone: +49 (0) 24 52 / 91 04 0
fax: +49 (0) 24 52 / 91 04 50
e-mail: info@sbh-tiefbautechnik.com
homepage: [http:// www.sbh-tiefbautechnik.com](http://www.sbh-tiefbautechnik.com)

Contents

| | |
|--|----|
| System drawing | 3 |
| Technical parameters | 4 |
| Plate thickness 107 mm & 127 mm | 4 |
| Spindles | 5 |
| Accessories | 5 |
| General instructions | |
| Lifting & transporting | 6 |
| Measures to reduce danger | 6 |
| Maintenance & repair | 6 |
| Assembly instructions | 7 |
| Installation instructions | 8 |
| Allowed tensile forces | 8 |
| Place and adjust method | 8 |
| Cut and lower method | 9 |
| Installation of the base boxes | 9 |
| Use of protection rails | 10 |
| Installation of top boxes | 10 |
| Installation of further shoring sections | 11 |
| Re-installation | 11 |

System drawing

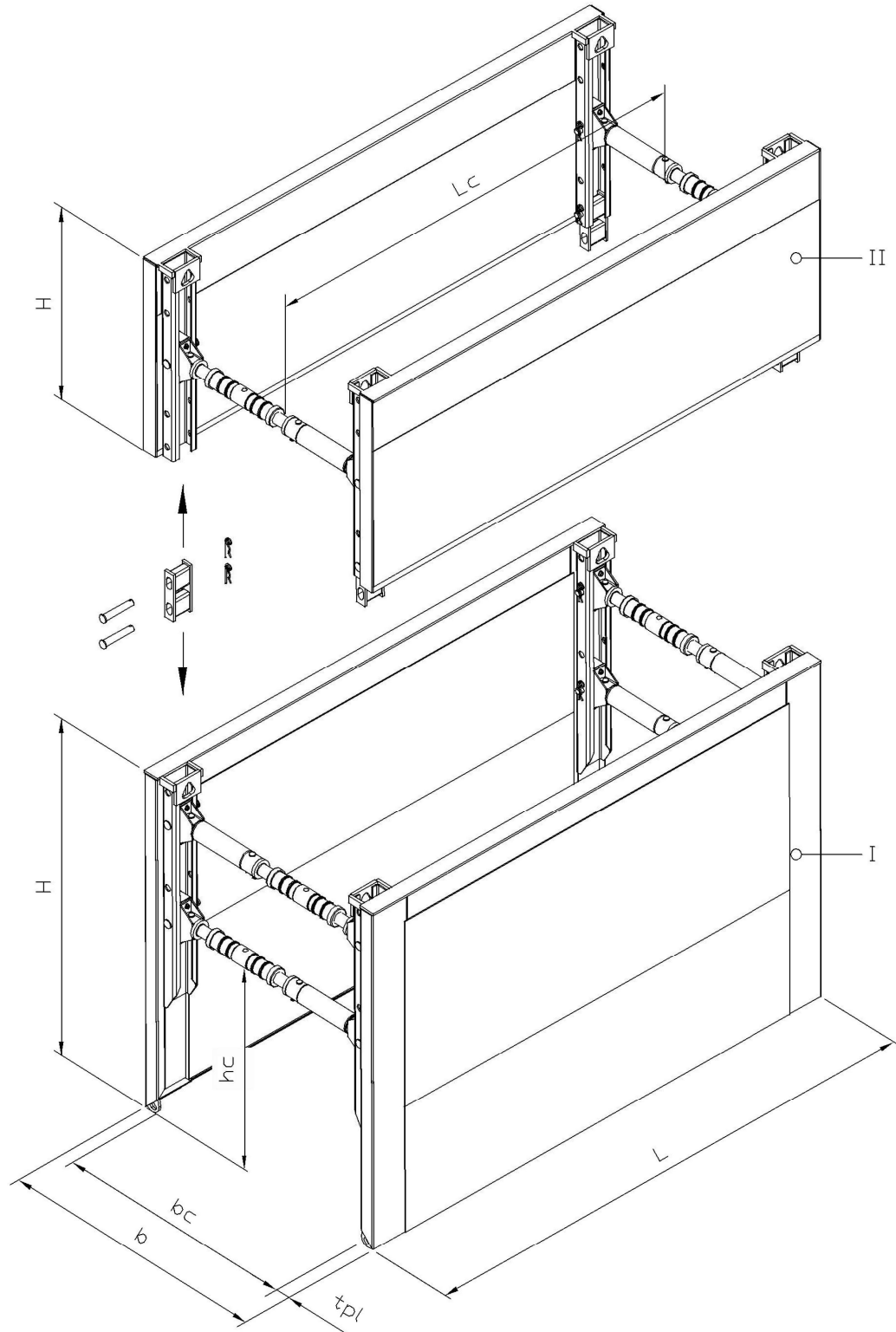

I base box
 II top box
 H plate height

b trench width
 b_c working width
 t_{Pl} plate thickness

h_c spindle clearance height
 L plate length
 L_c spindle clearance length

STANDARDBOX Series 600



Technical Parameter

Plate thickness = 107 mm

allowed plate moment = 79,1 kNm/m allowed side part moment = 78,6 kNm

| plate length L [m] | plate height H [m] | clearance length L _c [m] | clearance height h _c [m] | all. earth pressure [kN / m ²] | weight Box [kg] |
|----------------------------|----------------------------|---|---|---|-------------------------|
| 2,50 | 2,40 | 2,10 | 1,50 | 56,9 | 1740 |
| | 2,60 | | | | 1820 |
| | 1,40 | | | | 1060 |
| 3,00 | 2,40 | 2,60 | 1,50 | 47,5 | 1950 |
| | 2,60 | | | | 2075 |
| | 1,40 | | | | 1205 |
| 3,50 | 2,40 | 3,10 | 1,50 | 40,7 | 2180 |
| | 2,60 | | | | 2320 |
| | 1,40 | | | | 1350 |
| 3,70 | 2,40 | 3,30 | 1,50 | 38,5 | 2270 |
| | 2,60 | | | | 2445 |
| | 1,40 | | | | 1410 |
| 4,00 | 2,40 | 3,60 | 1,50 | 35,6 | 2400 |
| | 2,60 | | | | 2560 |
| | 1,40 | | | | 1495 |

Plate thickness = 127 mm

allowed plate moment = 100,2 kNm/m allowed side part moment = 94,2 kNm

| plate length L [m] | plate height H [m] | clearance length L _c [m] | clearance height h _c [m] | all. earth pressure [kN / m ²] | weight box [kg] |
|----------------------------|----------------------------|---|---|---|-------------------------|
| 4,50 | 2,40 | 4,10 | 1,50 | 33,7 | 2910 |
| | 2,60 | | | | 3090 |
| | 1,40 | | | | 1880 |
| 5,00 | 2,40 | 4,60 | 1,50 | 30,3 | 3160 |
| | 2,60 | | | | 3360 |
| | 1,40 | | | | 2050 |
| 5,50 | 2,40 | 5,10 | 1,50 | 27,6 | 3415 |
| | 2,60 | | | | 3635 |
| | 1,40 | | | | 2220 |
| 6,00 | 2,40 | 5,60 | 1,50 | 24,5 | 3670 |
| | 2,60 | | | | 3910 |
| | 1,40 | | | | 2390 |

Spindle

allowed moment = 1,7 kNm

allowed tensile force = 218 kN

| number of ext. pipes in 0,50 m | min working width b _c [m] | type 031/085 blue | | type 031/135 yellow | | weight total [kg] |
|--------------------------------------|--|--|--|--|--|---------------------------|
| | | max working width b _c [m] | allowed compressive force [kN] | max working width b _c [m] | allowed compressive force [kN] | |
| 0 | 0,98 | 1,26 | 468 | 1,16 | 510 | 65,0 |
| 1 | 1,48 | 1,76 | 403 | 1,66 | 445 | 84,8 |
| 2 | 1,98 | 2,26 | 348 | 2,16 | 394 | 104,6 |
| 3 | 2,48 | 2,76 | 299 | 2,66 | 354 | 124,4 |
| 4 | 2,98 | 3,26 | 254 | 3,16 | 321 | 144,2 |
| 5 | 3,48 | 3,76 | 210 | 3,66 | 292 | 164,0 |
| 6 | 3,94 | 4,26 | 165 | 4,16 | 263 | 183,8 |

STANDARDBOX Series 600



Accessories

| no. | description | use for | dimension [mm] | weight [kg] |
|-----|-----------------------|---------------------------------|------------------------|---------------|
| 1 | spring spindle holder | spindle | 95/290 * 193 | 13,1 |
| 2 | Spindle | plates | | 40,2 |
| 3 | pin with clip 4,5 | ext. pipe | ∅20 * 147 | 0,4 |
| 4 | pin with clip 6,3 | spr. spindle holder & connector | ∅40 * 230 | 2,4 |
| 5 | ext. Pipe | spindle | ∅121 * 500 ∅121 * L | 19,8 |

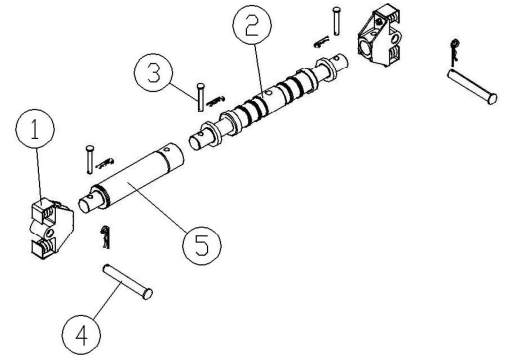

| | | | | |
|---|-----------|-----------|--------------|-----|
| 6 | Connector | top plate | 70/150 * 325 | 7,6 |
|---|-----------|-----------|--------------|-----|

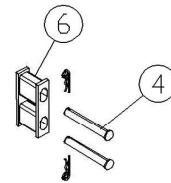

| | | | | |
|---|-----------------|-------------------|----------|-----|
| 7 | protection rail | plates t = 107 | L = 2730 | 321 |
| | | | L = 3300 | 379 |
| | | | L = 3510 | 399 |
| | | | L = 3800 | 430 |
| | | plates t = 127 | L = 4800 | 646 |
| | | | L = 5300 | 703 |
| | | L = 5800 | 760 | |

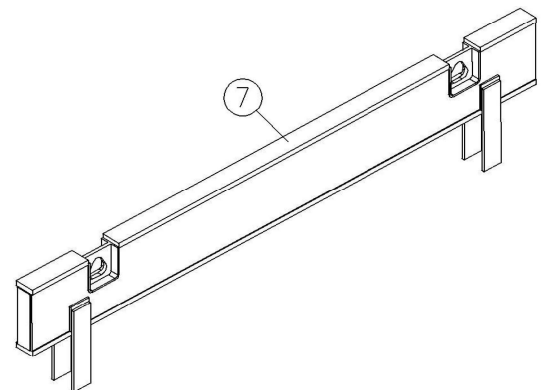

General instructions

The shoring must be without gap and close to the ground. The limiting values for the max. loads have to be kept strictly. Single shoring sections (boxes) may only be used if the front and rear faces are properly secured.

The following rules and regulations have to be followed in their valid version:

- Regulations of the BG-Fachausschuss Tiefbau (technical committee civil and underground engineering)
- DIN 4124 Baugruben und Gräben (excavation pits and trenches)
- DIN EN 13331 Teil 1 & 2 Grabenverbaugeräte (part 1 & 2 construction equipment)
- Regeln für Sicherheit und Gesundheit bei der Arbeit (rules for safety and health during work)
- Unfallverhütungsvorschriften / Arbeitsschutzvorschriften (accident prevention and safety at work rules)

Our shoring components have the GS-Sign „Certified Safety“.

During installation the instructions of this operating manual have to be followed.

Lifting & Transporting

- The shoring may only be attached at the corresponding eyes and openings and/or lifting accessories.
- The lifting accessories must be adapted to the weight which must be transported.
- For safety reasons only load hooks with hook safety must be used.
- The allowed tensile forces have to be kept in any case.
- The transporting has to be carried out next to the soil and unneeded pendulum movements have to be avoided.
- It is forbidden to enter the swivel range of the lifting tool and to stay under floating loads.
- It has to be paid attention to overhead contact lines.
- Engine driver and instructor must have face-to-face interaction.

Measures to reduce danger

- The construction site has to be sufficiently secured and marked.
- Neighbouring traffic flow has to be made possible by means of security personnel if needed.
- The personnel must wear protective clothing (helmet / safety shoes / gloves).
- Possible instabilities as a result of wind loads, during the assembly and installation, must be considered.
- The shoring components must be layed down – preferably in horizontal way – on a firm underground.
- In case of slopes it has to focus on a stable storage or mounting of pre-assembled components.

Maintenance & repair

- As a matter of principle, the operability of all shoring components must be checked before use.
- Defective or deformed components may not be used in any case.
- Slighter damages may be repaired by yourselves after consulting SBH. Otherwise, our service at SBH is at your disposal if desired.
- Only original spare parts of SBH may be used.
- According to intenseness of use, the components should be painted with anti-corrosive paint every 2 years.

Assembly instructions

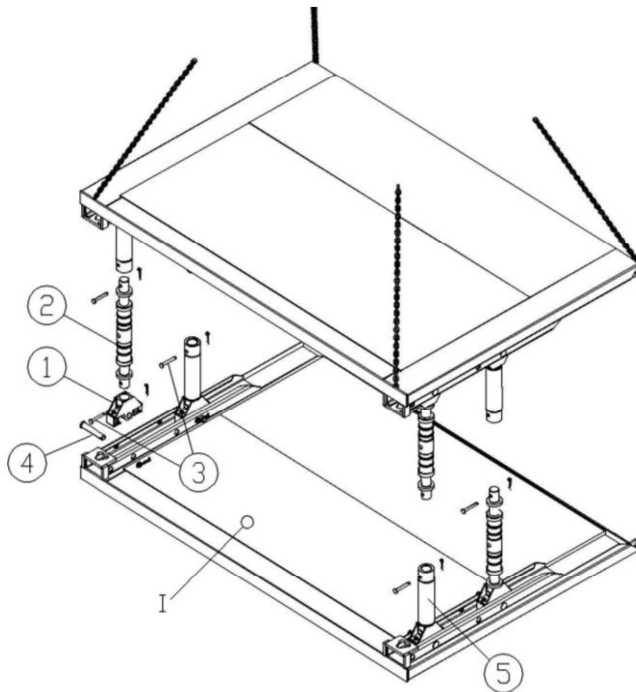

- | | | | | | |
|---|------------|---|---------------------------------|---|---------------------------------|
| I | base plate | 1 | spring spindle holder | 4 | pin $\varnothing 40 \times 230$ |
| | | 2 | casting spindle | 5 | extensionpipe |
| | | 3 | pin $\varnothing 20 \times 147$ | | |

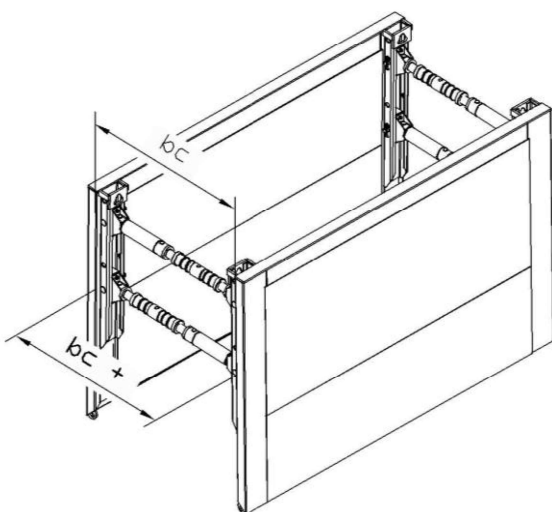

Put the base plates onto a flat and firm underground with the profile to the top.

Afterwards put the spring spindle holders into the profiles, fix with the pins $\varnothing 40 \times 230$ mm and secure by means of the clips.

Put the spindles and extension pipes, respectively staggered, into the spring spindle holders (trench widths up to 2,0 m at one plate – greater widths at two plates) and fix with the pin $\varnothing 20 \times 147$ mm. Secure the pin by means of the clip.

The extending up to the required trench width is effected by means of extension pipes as described above.

After mounting all spindles, one plate is connected to the corresponding lifting/transporting eyes at the top and cutting edge and then put from the top onto the spindle of the plate beneath, pinned and secured.

Now the spindles are extended/spindled out to the required trench width (find adjustment).

Thereby it has to be paid attention that the bottom strut is extended by about 3 – 5 cm more than the upper one, in order to achieve the A-position of the shoring plates.

The shoring width must be shorter above and more wide below.

The assembly of the top boxes is effected analogously.

Installation instructions

Allowed tensile forces

At the single attachment points the following tensile forces can be beared:

| | | |
|----------------------|----------------------------|----------|
| <i>SHORING PLATE</i> | per lifting eye at the top | = 153 kN |
| | per eye at cutting edge | = 49 kN |

Place and adjust method

The shoring box is placed into the totally pre-excavated trench.

The place and adjust method is allowed only if the following requirements are given:

- Temporary steady soil
- Outside of the sphere of buildings or structural plants
- Outside of the sphere of circulation spaces and endangered lines
- Settlements can be accepted

A soil is characterised as temporary steady if it does not have considerable collapses in the time between start of excavation and placing of the shoring.

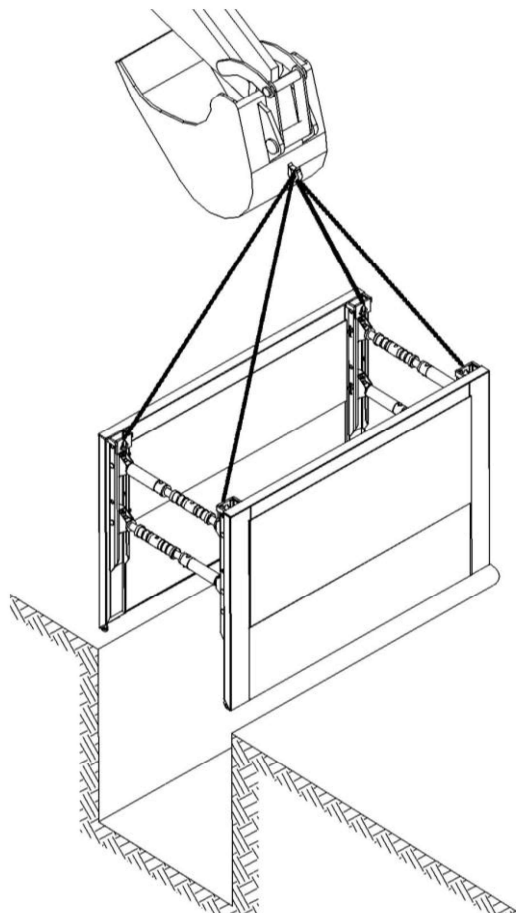

For trench depths greater than the base plate height, when applying the place and adjust method, base and top boxes must be assembled outside of the trench and placed into the trench as a whole.

Base and top boxes are connected by means of box connectors and pins and secured with clips.

Attach the chains to the provided eyes in the profile at least at four points.

Place the completely assembled base and top box as a whole into the entirely pre-excavated trench by means of lifting tools and appropriate lifting accessories.

The excavation length has to be limited to the box length.

The opening between shoring and soil has to be filled and compacted.!

Cut and lower method

In unsteady soils, the shoring has to be installed by alternately pushing in and lowering.

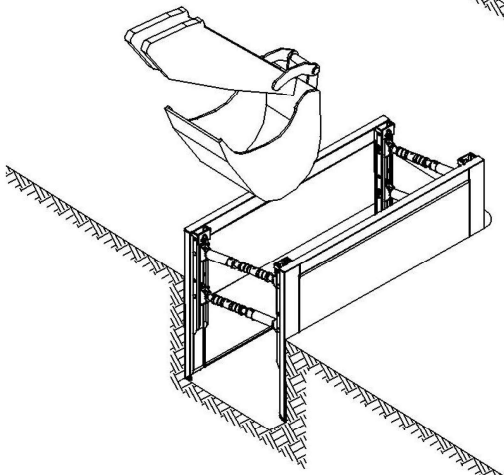
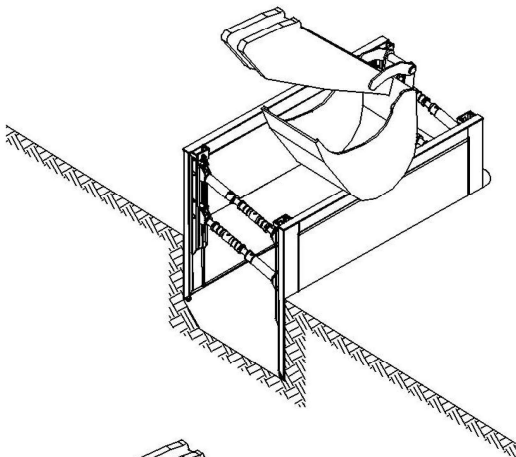
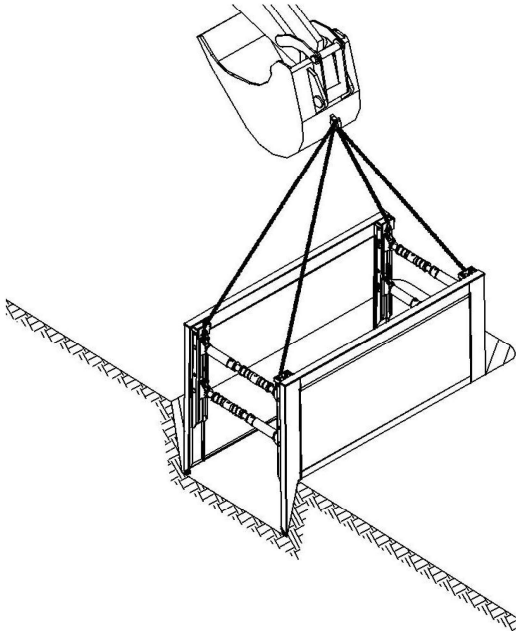

Installation of the base boxes

Pre-excavation max. 1,25 m and not more than one shoring section length. In principle the pre-excavation complies with the type of soil and safety regulations.

Attach the chains to the four eyes at the profile and place the base box which is spindled out to the required trench width, in the pre-excavated trench, align and push in.

Fill the opening between shoring and soil and compact!

The shoring plates are to be pushed in and not battered. For safety reasons it is not allowed to push the extension pipes.

In this phase the trench may not be entered.

Excavate about further 0,50m and alternately push in the plates.

The smaller the steps or pushes are carried out the better for the shoring! Do not push more than 50 cm the one side and limit the swivelling angle of the spindles to $\pm 8^\circ$.

Repeat this procedure until reaching the required trench depth.

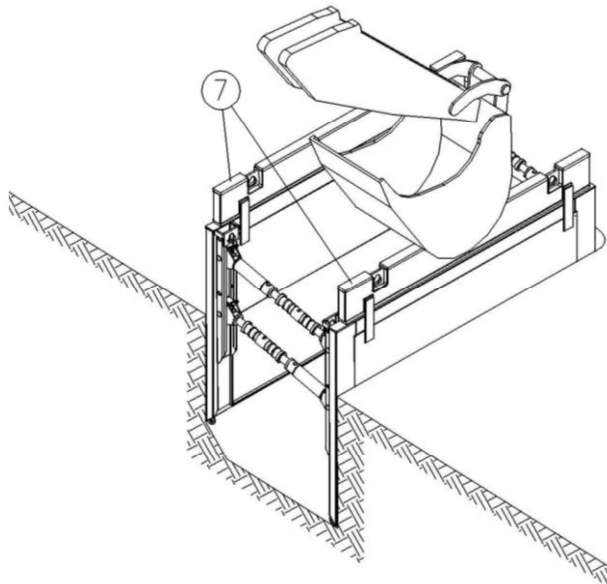

7 protection rail

Use of protection rails

To protect the shoring plates and ensure a long life cycle we recommend the use of protection rails.

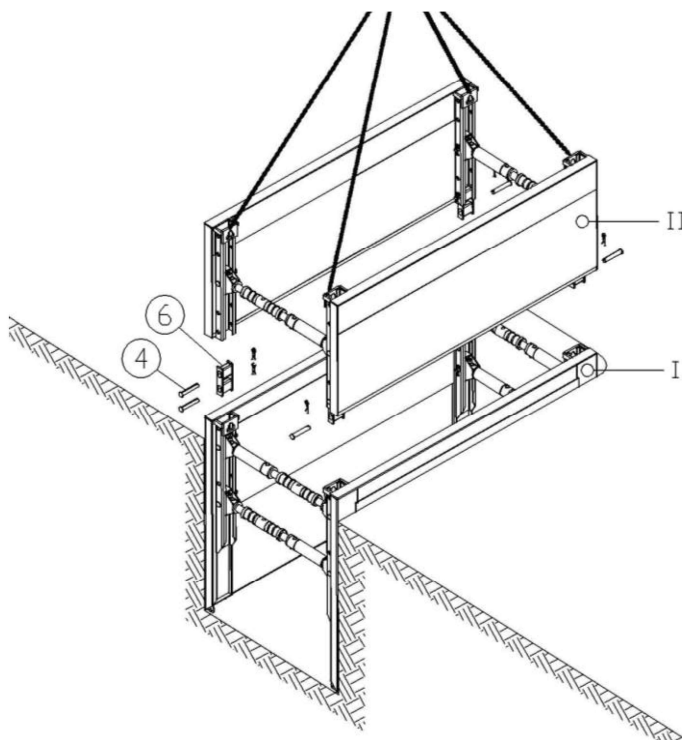

I base box
II top box

4 pin $\varnothing 40 \times 230$
6 connector

Installation of top boxes

For greater trench depths top boxes are to be used. The top box, pre-assembled to trench width, is attached to the four eyes at the profile, aligned over the base box described and connected by means of box connectors and pins $\varnothing 40 \times 230$ mm.

The further installation is effected as above by alternately excavating and pushing in of the shoring plates.

The top edge of the shoring must overlap the surrounding site by at least 5 cm!

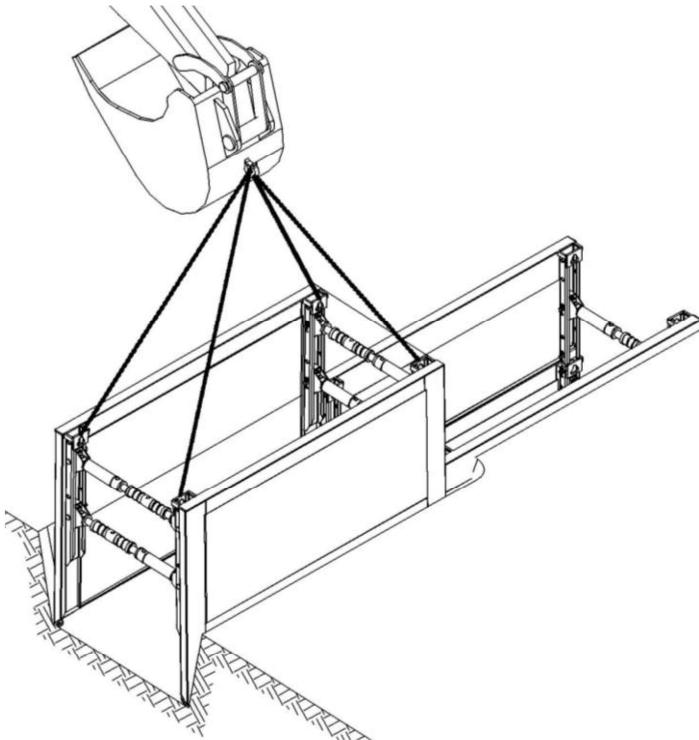

Installation of further shoring sections

Once the foregoing shoring section is installed to full depth, it can be started with the next shoring section..

The installation is effected analogously as described before.

After the installation of the shoring boxes, the pipe laying can be started in the shored and secured trench.

Re-installation

After completion of the pipe laying the re-installation of the shoring is effected.

According to compacting possibilities bring in about 0,50m filling material. Lift the shoring box by the filled height. That followed the compaction of the filling material.

The smaller the lifting steps the better for the shoring! Do not lift more than 0,50 cm to one side and limit the swivelling angle of the spindles to $\pm 8^\circ$.

Repeat this procedure as described until the shoring can be lifted out of the trench according to the safety regulations.

Only use the corresponding eyes for the lifting. It is not allowed to lift at the extension pipes!

We advise specifically that it is forbidden to enter the danger zone during the installation and re-installation.

In order to avoid an overstraining of the shoring plates, do not lift onesided. Attach lifting accessories at least at 2 eyes of the particular plate.

